

Accu-L[®] AEC-Q200 Qualified

High-Q RF Inductors - L0402 & L0805

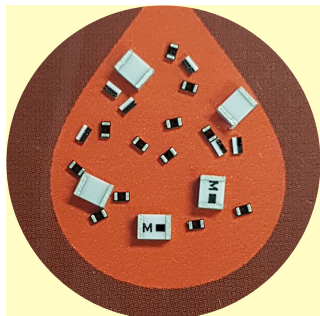

L0402 and L0805 Inductors

ACCU-L[®] TECHNOLOGY

The L0402 LGA Inductor and the L0805 Accu-L[®] SMD Inductor are based on thin-film multilayer technology. This technology provides a level of control on the electrical and physical characteristics of the component which gives consistent characteristics within a lot and lot-to-lot. The original design provides small size, excellent high-frequency performance and rugged construction for reliable automatic assembly.

The AEC-Q200 Qualified Accu-L[®] Series is designed to meet the demanding performance specifications in automotive signal and power applications.

FEATURES

- High Q
- RF Power Capability
- High SRF
- Low DC Resistance
- Ultra-Tight Inductance Tolerance
- Standard 0402 and 0805 Chip Sizes
- Low Profile
- Rugged Construction
- Taped and Reeled

Operating/Storage Temp. Range:
-55°C to +125°C

APPLICATIONS

- Vehicle to Vehicle Communications
- Infotainment
- Telematics
- GPS
- Radar
- Vehicle Locations Systems
- Keyless Entry
- Filters
- Matching Networks

0402 DIMENSIONS: millimeters (inches)

(Bottom View)

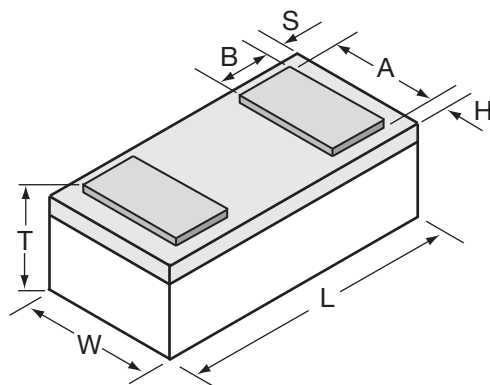

L	1.00±0.10 (0.039±0.004)
W	0.58±0.07 (0.023±0.003)
T	0.35±0.10 (0.014±0.004)

A	0.48±0.05 (0.019±0.002)
B	0.17±0.05 (0.007±0.002)
S, H	0.064±0.05 (0.003±0.002)

0805 DIMENSIONS: millimeters (inches)

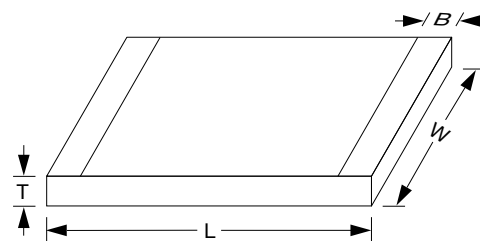

L	2.11±0.10 (0.083±0.004)
W	1.5±0.10 (0.059±0.004)
T	0.91±0.13 (0.036±0.005)
B	0.25±0.15 (0.010±0.006)



Accu-L® AEC-Q200 Qualified

High-Q RF Inductors - L0402 & L0805



HOW TO ORDER

L ↓	0805 ↓	4R7 ↓	D ↓	4 ↓	S ↓	TR ↓
Product Inductor	Size 0402 0805	Inductance Expressed in nH (2 significant digits + number of zeros) for values <10nH, letter R denotes decimal point. Example: 22nH = 220 4.7nH = 4R7	Tolerance A = ±0.05nH B = ±0.1nH C = ±0.2nH D = ±0.5nH G = ±2% J = ±5%	Specification Code 4 = AEC-Q200 Qualified Accu-L®	Termination Code S = Nickel/ Sn100 Lead Free Solder coated (L0805) N=Nickel/ Sn100 Lead Free Solder coated (L0402)	Packaging Code TR = Tape and Reel



Engineering Kits Available

ELECTRICAL SPECIFICATIONS TABLE FOR ACCU-L® 0402

L (nH)	450MHz			900MHz	1900MHz	2400MHz	SRF min. (MHz)	R _{DC} max. (Ω)	I _{DC} max. (mA)
	Tolerance A=±0.05nH, B=±0.1nH, C=±0.2nH, D=±0.5nH			Q (min)	Q (Typ)	Q (Typ)			
0.56	± 0.05nH, ± 0.1nH			35	45	55	20000	0.02	1000
0.68	± 0.05nH, ± 0.1nH			30	40	50	20000	0.04	750
0.82	± 0.05nH, ± 0.1nH			25	40	50	20000	0.06	500
1.0	± 0.05nH, ± 0.1nH			20	30	35	20000	0.15	500
1.2	± 0.05nH, ± 0.1nH, ± 0.2nH			20	30	30	20000	0.20	400
1.5	± 0.05nH, ± 0.1nH, ± 0.2nH			20	25	30	18000	0.20	400
1.8	± 0.05nH, ± 0.1nH, ± 0.2nH			18	20	30	16000	0.20	400
2.2	± 0.05nH, ± 0.1nH, ± 0.2nH			15	20	25	15000	0.20	400
2.7	± 0.05nH, ± 0.1nH, ± 0.2nH			15	20	25	9500	0.25	250
3.3	± 0.1nH, ± 0.2nH, ± 0.5nH			15	20	25	8500	0.40	250
3.9	± 0.1nH, ± 0.2nH, ± 0.5nH			13	20	20	8000	0.45	250
4.7	± 0.1nH, ± 0.2nH, ± 0.5nH			13	20	20	7500	0.45	250
5.6	± 0.1nH, ± 0.2nH, ± 0.5nH			13	20	20	7000	0.65	200
6.8	± 0.1nH, ± 0.2nH, ± 0.5nH			12	15	20	6500	0.90	200

Please contact factory for intermediate inductance values within the indicated range.

ELECTRICAL SPECIFICATIONS TABLE FOR ACCU-L® 0805

Inductance L (nH)	450 MHz Test Frequency		900 MHz Test Frequency		1700 MHz Test Frequency		2400 MHz Test Frequency		SRF min (MHz)	R _{DC} max (Ω)	I _{DC} max (mA)	
	Available Inductance Tolerance	Q Typical	L (nH)	Q Typical	L (nH)	Q Typical	L (nH)	Q Typical			ΔT = 15°C (1)	ΔT = 70°C (2)
1.2	±0.1nH, ±0.2nH, ±0.5nH	60	1.2	92	1.2	122	1.2	92	10000	0.05	1000	2000
1.5	±0.1nH, ±0.2nH, ±0.5nH	50	1.5	74	1.5	102	1.5	84	10000	0.05	1000	2000
1.8	±0.1nH, ±0.2nH, ±0.5nH	50	1.8	72	1.8	88	1.9	73	10000	0.06	1000	2000
2.2	±0.1nH, ±0.2nH, ±0.5nH	42	2.2	62	2.2	82	2.3	72	10000	0.07	1000	2000
2.7	±0.1nH, ±0.2nH, ±0.5nH	42	2.7	62	2.8	80	2.9	70	10000	0.08	1000	2000
3.3	±0.1nH, ±0.2nH, ±0.5nH	38	3.3	46	3.4	48	3.5	57	10000	0.11	750	1500
3.9	±0.1nH, ±0.2nH, ±0.5nH	27	3.9	36	4.0	38	4.1	42	10000	0.20	750	1500
4.7	±0.1nH, ±0.2nH, ±0.5nH	43	4.8	62	5.3	76	5.8	60	5500	0.10	750	1500
5.6	±0.5nH	50	5.7	68	6.3	73	7.6	62	4600	0.10	750	1500
6.8	±0.5nH	43	7.0	62	7.7	71	9.4	50	4500	0.11	750	1500
8.2	±0.5nH	43	8.5	56	10.0	55	15.2	32	3500	0.12	750	1500
10	±2%, ±5%	46	10.6	60	13.4	52	-	-	2500	0.13	750	1500
12	±2%, ±5%	40	12.9	50	17.3	40	-	-	2400	0.20	750	1500
15	±2%, ±5%	36	16.7	46	27	23	-	-	2200	0.20	750	1000
18	±2%, ±5%	30	21.9	27	-	-	-	-	1700	0.35	500	1000
22	±2%, ±5%	36	27.5	33	-	-	-	-	1400	0.40	500	1000

(1) I_{DC} measured for 15°C rise at 25°C ambient temperature
 (2) I_{DC} measured for 70°C rise at 25°C ambient temperature

L, Q, SRF measured on HP 4291A, Boonton 34A and Wiltron 360 Vector Analyzer, R_{DC} measured on Keithley 580 micro-ohmmeter.



Accu-L[®] AEC-Q200 Qualified

High-Q RF Inductors - L0402 & L0805



**Typical Q vs. Frequency
L0805**

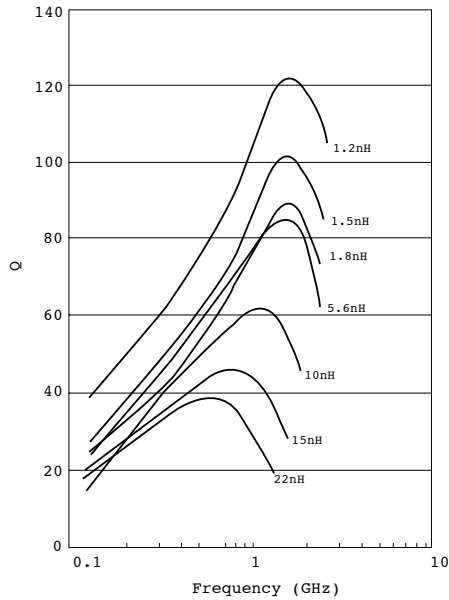

Measured on HP4291A and
Boonton 34A Coaxial Line

**Typical Inductance vs. Frequency
L0805**

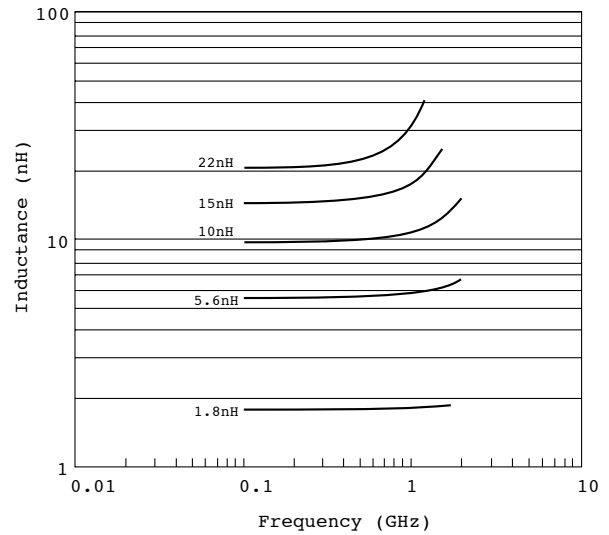

Measured on HP4291A and
Wiltron 360 Vector Analyzer

**Maximum Temperature Rise
at 25°C ambient temperature (on FR-4)
L0805**

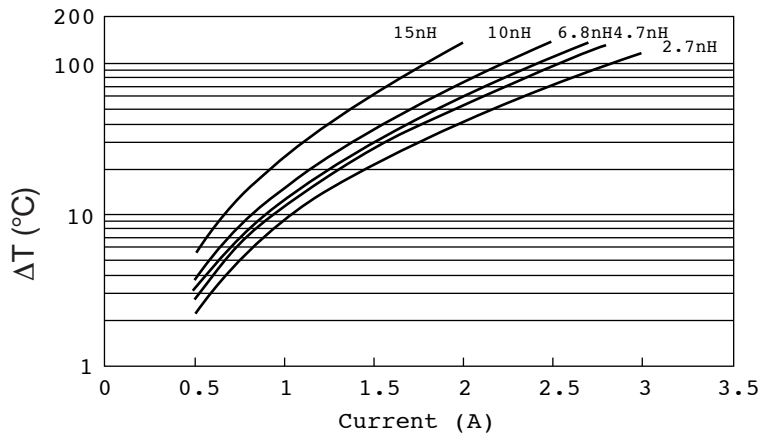

Temperature rise will typically be no higher than shown by the graph



Accu-L® AEC-Q200 Qualified

High-Q RF Inductors - L0402 & L0805



FINAL QUALITY INSPECTION

Finished parts are tested for electrical parameters and visual/mechanical characteristics.

Parts are 100% tested for inductance at 450MHz. Parts are 100% tested for R_{DC} . Each production lot is evaluated on a sample basis for:

- Q at test frequency
- Static Humidity Resistance: 85°C, 85% RH, 160 hours
- Endurance: 125°C, I_R , 4 hours

ENVIRONMENTAL CHARACTERISTICS

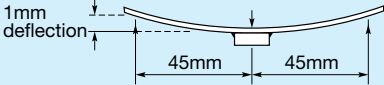
TEST	CONDITIONS	REQUIREMENT
Solderability	Components completely immersed in a solder bath at $235 \pm 5^\circ\text{C}$ for 2 secs.	Terminations to be well tinned. No visible damage.
Leach Resistance	Components completely immersed in a solder bath at $260 \pm 5^\circ\text{C}$ for 60 secs.	Dissolution of termination faces $\leq 15\%$ of area. Dissolution of termination edges $\leq 25\%$ of length.
Storage	12 months minimum with components stored in "as received" packaging.	Good solderability
Shear	Components mounted to a substrate. A force of 5N applied normal to the line joining the terminations and in a line parallel to the substrate.	No visible damage
Rapid Change of Temperature	Components mounted to a substrate. 5 cycles -55°C to $+125^\circ\text{C}$.	No visible damage
Bend Strength	Tested as shown in diagram 	No visible damage
Temperature Coefficient of Inductance (TCL)	Component placed in environmental chamber -55°C to $+125^\circ\text{C}$.	+0 to +125 ppm/ $^\circ\text{C}$ (typical) $\text{TCL} = \frac{L_2 - L_1}{L_1 (T_2 - T_1)} \cdot 10^6$ $T_1 = 25^\circ\text{C}$

Accu-L® AEC-Q200 Qualified

High-Q RF Inductors - L0402 & L0805



HANDLING

SMD chips should be handled with care to avoid damage or contamination from perspiration and skin oils. The use of plastic tipped tweezers or vacuum pick-ups is strongly recommended for individual components. Bulk handling should ensure that abrasion and mechanical shock are minimized. For automatic equipment, taped and reeled product is the ideal medium for direct presentation to the placement machine.

CIRCUIT BOARD TYPE

All flexible types of circuit boards may be used (e.g. FR-4, G-10) and also alumina.

For other circuit board materials, please consult factory.

COMPONENT PAD DESIGN

Component pads must be designed to achieve good joints and minimize component movement during soldering.

Pad designs are given below for both wave and reflow soldering.

The basis of these designs is:

- Pad width equal to component width. It is permissible to decrease this to as low as 85% of component width but it is not advisable to go below this.
- Pad overlap about 0.3mm.
- Pad extension about 0.3mm for reflow.
Pad extension about 0.8mm for wave soldering.

REFLOW SOLDERING

DIMENSIONS: millimeters (inches)

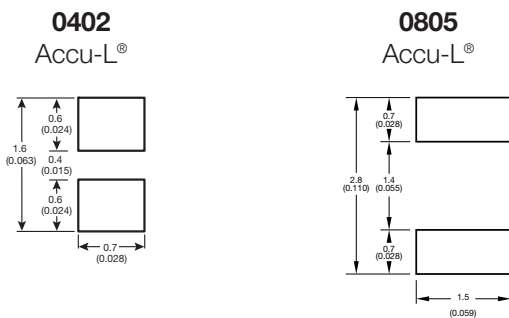

PREHEAT & SOLDERING

The rate of preheat in production should not exceed 4°C/second. It is recommended not to exceed 2°C/second. Temperature differential from preheat to soldering should not exceed 150°C.

For further specific application or process advice, please consult AVX.

HAND SOLDERING & REWORK

Hand soldering is permissible. Preheat of the PCB to 100°C is required. The most preferable technique is to use hot air soldering tools. Where a soldering iron is used, a temperature controlled model not exceeding 30 watts should be used and set to not more than 260°C. Maximum allowed time at temperature is 1 minute. When hand soldering, the base side (white side) must be soldered to the board.

COOLING

After soldering, the assembly should preferably be allowed to cool naturally. In the event of assisted cooling, similar conditions to those recommended for preheating should be used.

CLEANING RECOMMENDATIONS

Care should be taken to ensure that the devices are thoroughly cleaned of flux residues, especially the space beneath the device. Such residues may otherwise become conductive and effectively offer a lossy bypass to the device. Various recommended cleaning conditions (which must be optimized for the flux system being used) are as follows:

- Cleaning liquids i-propanol, ethanol, acetylacetone, water, and other standard PCB cleaning liquids.
- Ultrasonic conditions . . . power – 20w/liter max.
frequency – 20kHz to 45kHz.
- Temperature 80°C maximum (if not otherwise limited by chosen solvent system).
- Time. 5 minutes max.

STORAGE CONDITIONS

Recommended storage conditions for Accu-L® prior to use are as follows:

- Temperature. 15°C to 35°C
- Humidity ≤65%
- Air Pressure 860mbar to 1060mbar

RECOMMENDED SOLDERING PROFILE

